

LEVELING CASTERS

>>> Plate and Stud Type Mounts

This Level Caster Product fits every mounting requirement neatly into one package; offering the functionality of three products built into one unit.

The Level Caster incorporates a high-grade nylon wheel for easy movement, a mount for precise leveling, and a pad for anti-vibration control.



ADVANTAGES

- >> Anti-vibration control
- >> Easy hand leveling adjustment
- >> 360° freedom of motion
- >> Die-cast aluminium frame
- >> Dual mounting designs
- >> High quality nylon wheel

APPLICATIONS

- >> PACKAGING EQUIPMENT
- >> WORKSTATIONS
- >> TELECOMMUNICATIONS RACKS
- >> ASSEMBLY EQUIPMENT
- >> ELECTRONICS MANUFACTURING EQUIPMENT

Type A



SLC-300S - Stud Mount

Type B



SLC-200SL - Stud Mount

Type C



SLC-400PL - Plate Mount



SLC-200PL - Plate Mount



SLC-50PL - Plate Mount

LEVELING CASTERS

**Dimensioned Drawing
SLC Type A: Stud Mounting**

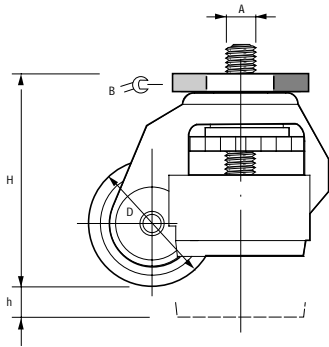

**Dimensioned Drawing
SLC Type A: Plate Mounting**

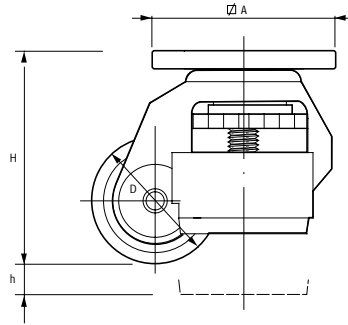

**Assembly example
SLC Type A: Plate Mounting**

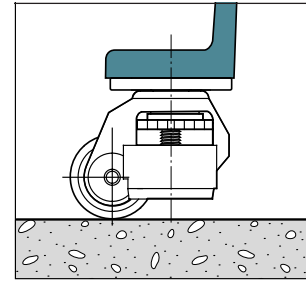

 sunnex

Stud Mounting

Model	Type	Load Capacity max, kg	Height, H mm	Adjustment, h mm	Wheel Dia., D mm	Thread type A	Depth mm	Stud area mm
SLC-50C	A	20	71	10	42	M8	12	40
SLC-200SL	B	90	71	9	50	M12	15	46
SLC-300S	A	130	83	10	50	M12	15	46
SLC-600S	A	270	102	15	63	M12	15	65
SLC-1000S	A	450	120	18	72	M16	16	70
SLC-1300S*	A	590	121	18	72	M16	16	70

Plate Mounting

Model	Type	Load Capacity max, kg	Height, H mm	Adjustment, h mm	Wheel Dia., D mm	Hole Dia. mm	Hole, CL mm	Plate, L x W mm
SLC-200PL	B	90	71	9	50	7	58	73
SLC-300P	A	130	83	10	50	7	58	73
SLC-400PL	C	180	76	10	50	9	70	90
SLC-600P	A	270	102	15	63	9	70	90
SLC-800PL	C	360	95	13	72	9	70	90
SLC-1000P	A	450	120	18	72	11	70	95
SLC-1300P*	A	590	121	18	72	11	70	95
SLC-1800P*	A	800	130	25	92	13	70	100

*Level tool required for adjustment